



1-SL-C-2D-2D-2D
3 sets of 2 Drawers with Saladette on Top

CHILLER

TECHNICAL DATA

Temperature Range	+2°C to +4°C
Dimensions	1800 x 800 x 880 1040
Refrigerated Volume	450 L
Refrigeration System	Air Cooled Forced Ventilated System
Refrigerant	R290 R404a
Insulation (50-70mm)	HFO PUR
Defrost	Electric Hot gas
Voltage	220-240V 50-60Hz
Power Rating	0.32 KW



FEATURES

- Digital controller (IP55)
- Three sets of two drawers
- Open structure accommodates 9 GN 1/3 Pans
- Hygiene internal corners
- Interior & Exterior (front, top, & 2 sides) in AISI 304
- Castors

OPTIONS

- Locking kit
- Adjustable legs
- Remote compressor
- Water cooled compressor
- Special finish
- Grade 316 AISI
- Custom handles
- Tropicalized
- Set of triple drawers

TECHNICAL DRAWINGS

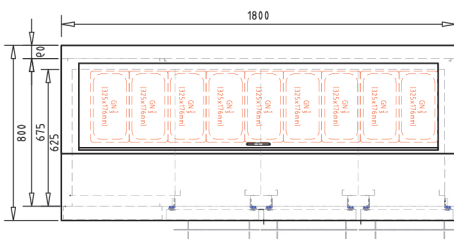

Top view

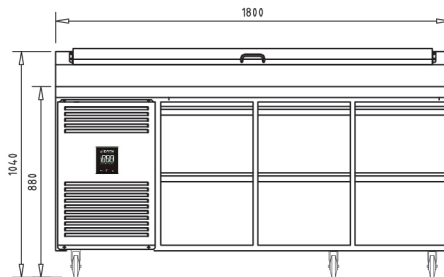

Front view

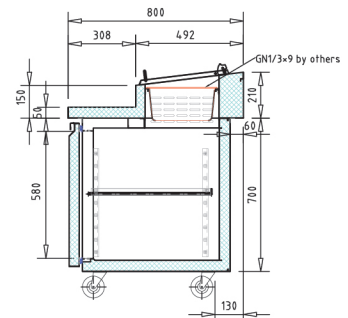

Section view