



**TECHNICAL DATA**

Temperature Range	+2° to +4°C
Dimensions	1800 x 800 x 880/1040
Refrigerated Volume	450 L
Refrigeration System	Air Cooled   Forced Ventilated System
Refrigerant	R404a (R290 Optional)
Insulation (50mm)	CFC free Cyclopentane
Defrost	Electric   Hot gas
Voltage	220-240V   50-60Hz

**FEATURES**

- Digital controller (IP55)
- Three 120° openable stainless steel doors
- One wire shelf per door
- Open structure accommodates 9 GN 1/3 Pans
- Hygiene internal corners
- Interior & Exterior (front, top, & 2 sides) in AISI 304 S/S

**OPTIONS**



- Legs
- Water cooled | Remote compressor

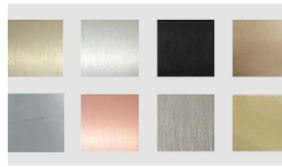

- Special finish | Grade 316
- Acrylic cover



- Half | Triple drawers

**TECHNICAL DRAWINGS**

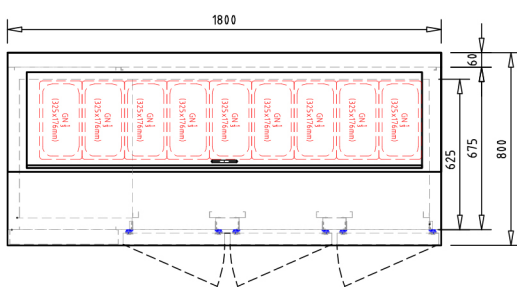

Top view

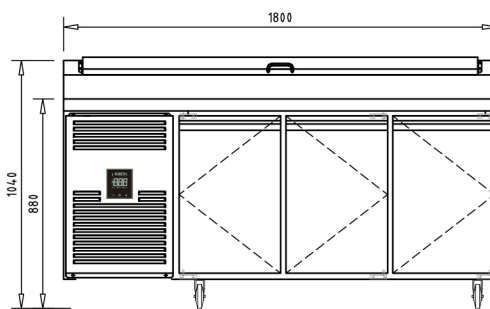

Front view

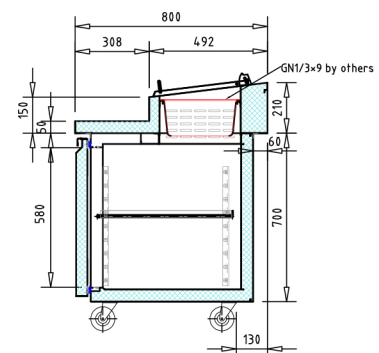

Section view