



**TECHNICAL DATA**

Temperature Range	-18° to 22°C
Dimensions	870 x 700 x 850
Refrigerated Volume	130 L
Refrigeration System	Air Cooled   Forced Ventilated System
Refrigerant	R404a (R290 Optional)
Insulation (50mm)	CFC free Cyclopentane
Defrost	Electric   Hot gas
Voltage	220-240V   50-60Hz

**FEATURES**

- Digital controller (IP55)
- One set of half stainless steel drawers
- Hygiene internal corners
- Interior & Exterior (front, top, & 2 sides) in AISI 304 S/S
- Legs

**OPTIONS**



- Locking kit
- Glass door

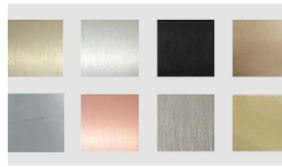

- Special finish | Grade 316
- Water cooled | Remote compressor



- Castors
- Worktop with backsplash



**TECHNICAL DRAWINGS**

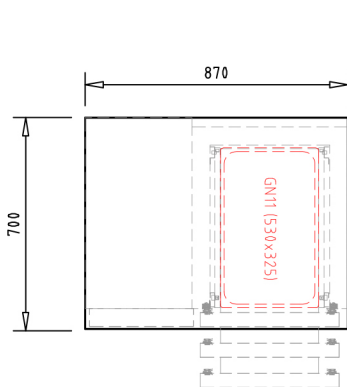

Top view

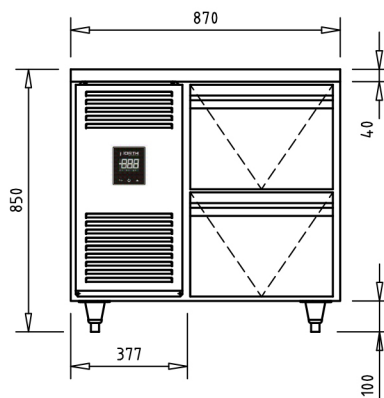

Front view

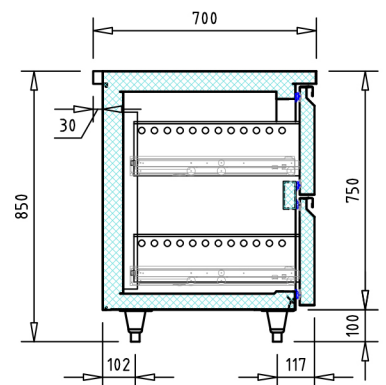

Section view