



**TECHNICAL DATA**

Temperature Range	-18° to -22°C
Dimensions	900 x 505 x 840
Refrigerated Volume	200 L
Refrigeration System	Air Cooled   Forced Ventilated System
Refrigerant	R404a (R290 Optional)
Insulation (50mm)	CFC free Cyclopentane
Defrost	Electric   Hot gas
Voltage	220-240V   50-60Hz

**FEATURES**

- Digital controller (IP55)
- Two 120° openable glass doors
- Self-closing hinges
- Two wire shelves
- Interior & Exterior (front, top, & 2 sides) in AISI 304 S/S
- Locking Kit

**OPTIONS**



- Custom racks
- Water cooled | Remote compressor

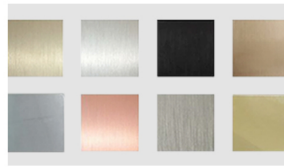

- Special finish | Grade 316
- Special glass finish



- Interior dimmable light



**TECHNICAL DRAWINGS**

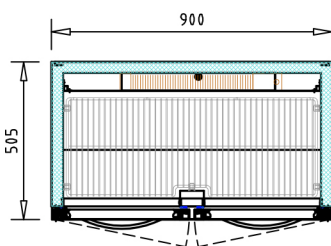

Top view

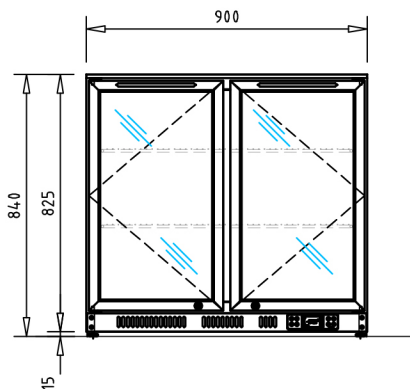

Front view

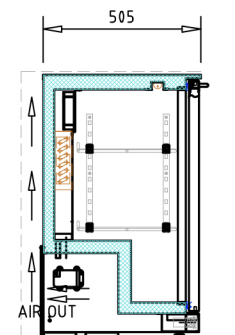

Section view