

American Line

TECHNICAL DATA

Temperature Range	+2° to +8°C
Dimensions	1529 x 750 x 895
Refrigerated Volume	428 L
Refrigeration System	Air Cooled Forced Ventilated System
Refrigerant	R134a (R290 Optional)
Insulation (50mm)	CFC free Cyclopentane
Defrost	Electric Hot gas
Voltage	220-240V 50-60Hz

FEATURES

- Digital controller (IP55)
- Two 120° openable stainless steel doors
- One wire shelf per door
- Hygiene internal corners
- Interior & Exterior (front, top, & 2 sides) in AISI 304 S/S
- Castors



OPTIONS



- Locking kit
- Glass door

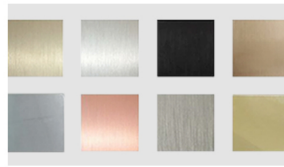

- Special finish | Grade 316
- Water cooled | Remote compressor



- Legs
- Worktop

TECHNICAL DRAWINGS

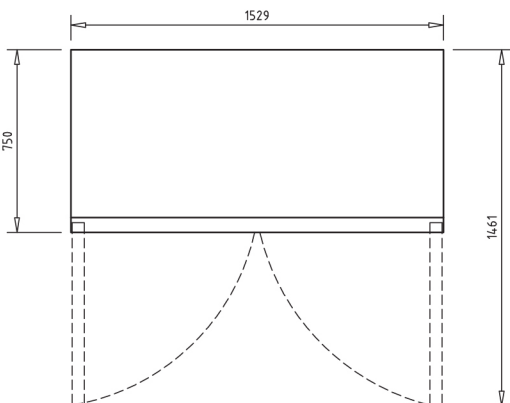

Top view

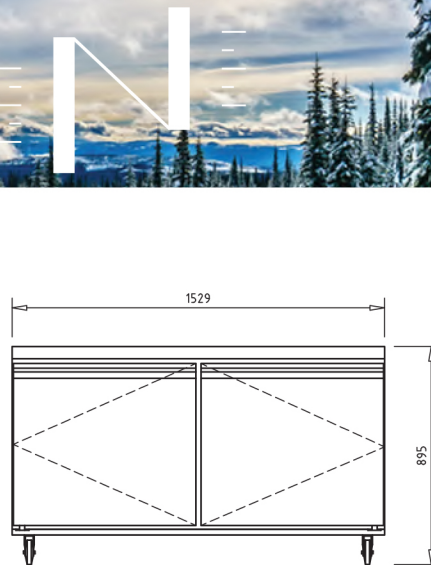

Front view

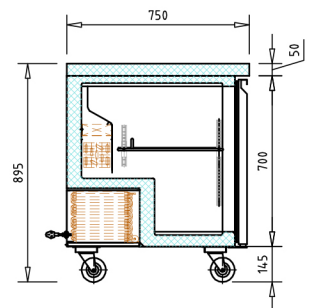

Section view

